

# APPEC Technology Forum 2018

---



Active and passive



stabilization  
systems

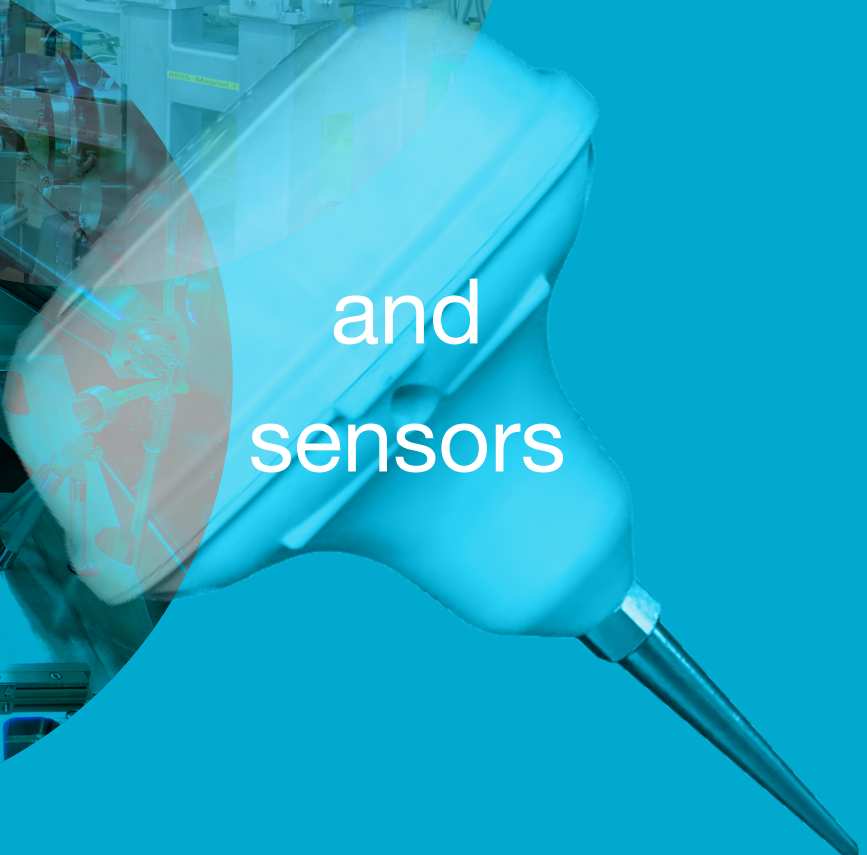

and  
sensors



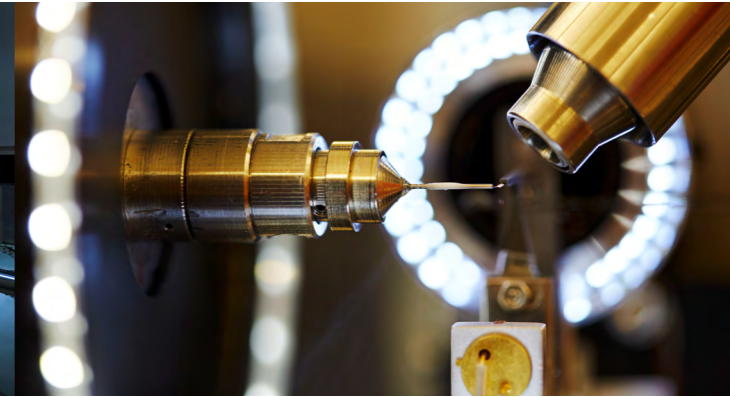
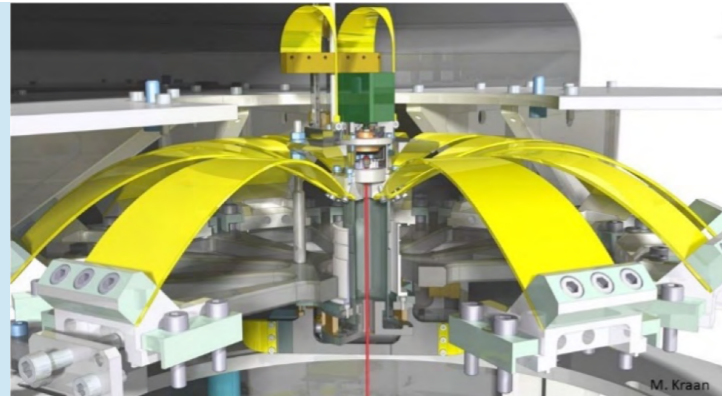

# Active and passive stabilization

In the last decades, it has become evident that often new breakthroughs in science are only possible if limits in the precision of certain measurements are overcome. The strategies can be different depending on the scientific goal. For example, a physical effect has to be revealed, or physical quantities have to be measured more accurately in order to set an upper/lower limit to an unknown physical entity.

Such efforts correspond to technological challenges that have to be tackled in order to reach the next level of precision, meaning e.g. a substantial reduction of noise. Typically, in an elaborated experiment many sources of noise are present and have to be all simultaneously mitigated. In these situations, the solution to every isolated issue is not enough, because the compatibility to the whole system represents a combined challenge.

## The APPEC Technology Forum 2018: aim and history

Starting in 2010, a series of dedicated academia and industry events have been organized in the frame of ASPERA, the EU-funded network of national funding agencies active in the domain of astroparticle physics. Since 2013, this work is continued by APPEC, the Astroparticle Physics European Consortium.

One of the major aims of an APPEC Technology Forum (ATF) is to foster the cooperation and exchange between academia and industry. In this format, it is foreseen that researchers from different scientific fields can present a specific technical case inherent to the main topics of that ATF edition, focusing on the challenges that have to be faced.

In 2017 and 2018, many experiments coordinated in large facilities down to medium-sized

collaboration were experiencing challenges in stabilization with respect to planned future developments. From these common issues, arose a diffuse interest in the discussion of active and passive stabilization systems with a broad interdisciplinary audience in an ATF, as it has never been done before.

In the particle- and astroparticle-physics communities the topic is of extreme interest.

For the construction of the 3<sup>rd</sup>-generation gravitational-wave (GW) detectors, active and passive stabilization techniques are important in the suspension and stabilization of the mirrors for the reduction of the noise in the whole spectrum of detection. Furthermore, it is necessary to measure and compensate for the surrounding seismic activity, that threatens the sensitivity of the antennas mostly at low frequencies, while electronic noise in the identification of the signal has to be suppressed. At the ATF 2018, possible solutions to these challenges elaborated at the Precision Mechatronics Laboratory of the Université Libre de Bruxelles, the INFN (Istituto Nazionale di Fisica Nucleare) in Pisa, the James Watt Nanofabrication Centre of the University of Glasgow and the University of Sheffield have been presented and proposed as viable techniques in other fields.

In numerous current particle-physics experiments, seismic isolation and precise positioning of components are crucial issues for reaching the needed sensitivity in challenging measurements and construction of new facilities. ALPS II, the second phase of the Any Light Particle Search, the light-shining-through-a-wall experiment searching for undiscovered sub-eV elementary particles, requires a control scheme of the noise from 0.1 Hz up to several kHz and seismic noise is one of the most challenging noise sources to be suppressed. The MAgnetized Disk and Mirror Axion eXperiment (MADMAX) will search for dark matter axions and will need to precisely position

and stabilize dielectric disks in a high-vacuum and cryogenic environment subject to a strong magnetic field. With the future perspective of building multi-TeV colliders, CERN in Geneva is collaborating with the Joint Institute for Nuclear Research (JINR) in the Moscow area for the development of a high-precision metrology instrumentation for the detection and compensation of seismic events. The INFN project GINGER – Gyroscopes IN GEneral Relativity has the aim of measuring the Lense-Thirring effect induced by the Earth with 1% relative precision, but its setup, based on large-frame ring-laser gyroscopes, and the one of its prototype (GINGERINO) have an application to seismology, because they can provide a measurement of rotation usually not surveyed by geophysicists.

The KARlsruhe TRitium Neutrino (KATRIN) experiment aims at a direct neutrino mass determination with a sensitivity of 200 meV/c<sup>2</sup> by precise spectroscopy of the tritium-β-decay electrons near the kinematic endpoint of 18.6 keV. This experiment is an example of combination of different precision challenges in terms of calibration and stabilization of pressure, temperature and composition of the source and of the high voltage in their spectrometer.

In the field of photon science, large facilities such as European XFEL and PETRA IV in the Hamburg area are under different stages of development, requiring dedicated studies for positioning and stabilization improvement. European XFEL, the X-ray Free-Electron-Laser facility, is under commissioning phase and to fulfill the requirements of a 4<sup>th</sup>-generation X-ray source, engineering, metrologic and high-precision challenges have to be faced. PETRA IV aims to become a diffraction-limited radiation source approaching a brilliance close to the fundamental physical limits for X-ray energies up to 10 keV and able to spatially resolve in the range 1-10 nm. This implies the es-

tablishment of a strategy to improve the present stabilization scheme implemented in the running system of PETRA III. In PETRA IV, the full chain of beam source, optics systems, sample and detector will need to be the most stable possible.

Scientists and engineers from the aforementioned institutions and collaborations had the opportunity to discuss with each other and with developers from industry. They represented well-established enterprises as well as freshly founded spin-off companies, who introduced their expertise in specific development areas inspiring new possible collaborations. Furthermore, an interesting demonstration of GW, their detection, seismic isolation technology and sensing by Nikhef, the Dutch National Institute for Subatomic Physics, took place during the breaks.

In-depth discussions of the current challenges of a few topics are also part of the format of an ATF. This year, we concentrated on three experiments and their present demands: CERN and JINR, MADMAX and European XFEL.

The open session had the structure of a brainstorming, where at first the speakers from the three fields introduced in detail the main and sub-challenges they are facing at the moment. Then the audience from science and industry split in three groups, depending on the personal interest and expertise. At last, the dedicated group of experts engaged in a deep discussion and exchange with the presenters and the other participants in the group, giving fruitful suggestions and contacts to other scientists and companies.

In order to facilitate the communication and the creativity in the brainstorming, flipcharts and the first module of the LEGO® SERIOUS PLAY® method have been implemented. This approach teaches how to metaphorically represent the suggestions with LEGO® bricks and has been briefly introduced at the beginning of the session.

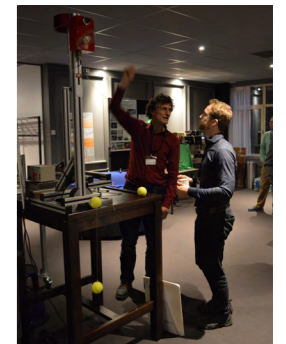

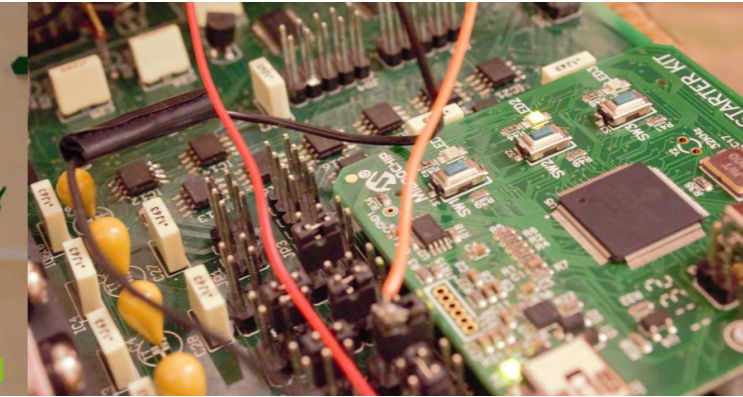
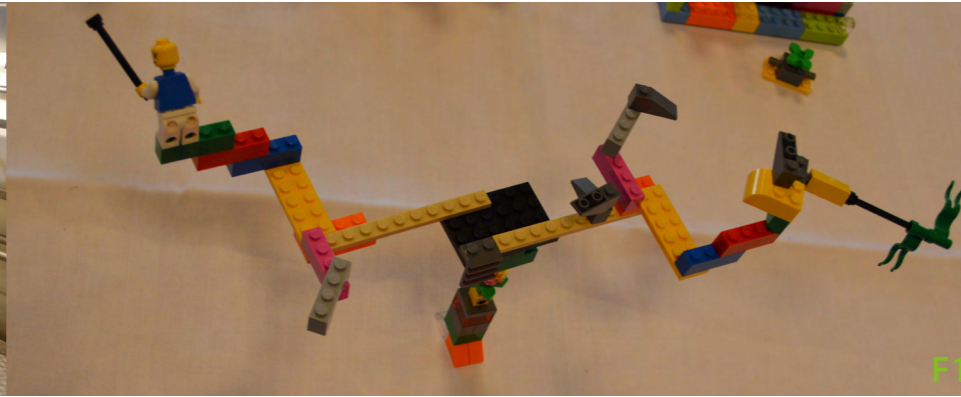
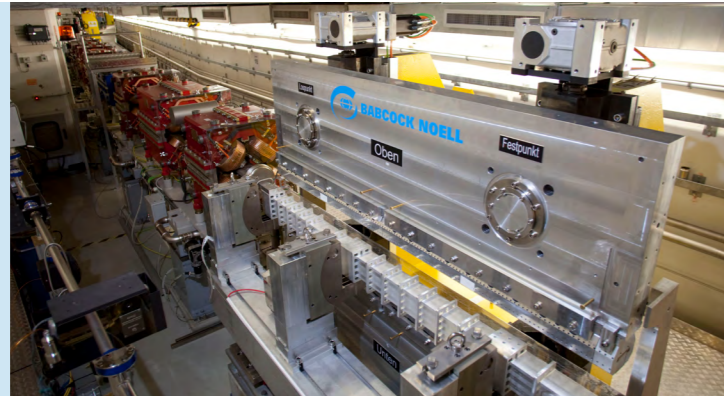

## The APPEC Technology Forum 2018: what we have learnt

### @CERN and JINR

Multi-TeV colliders are the future of CERN and at this energy level the impact of natural and human-originated seismic events on colliding beams is potentially severe, especially for e<sup>+</sup>e<sup>-</sup> accelerators. For this reason, in collaboration with JINR, previous studies on cavern stability have been extended and deepened, with the aim of setting up a very high precision metrology instrumentation able to detect and compensate for seismic events, also at the level of micro-seismic noise. Yearly drifts and lifts and micro-seismic effects correlated to the length of the focusing section of colliders, can induce displacements of the order of 100 μm, while, depending on the collider geometry and aim, e.g. the required size of the focus or beam size at the collision can be 1 to 3 orders of magnitude smaller.

At the ATF 2018, the attention was focused on the development of the Precision Laser Inclinometer (PLI). It is a relatively compact and cheap device based on laser deployment, able to detect the displacement of a laser beam reflected from a liquid surface when the base support is tilted by ground oscillations. Few units can be produced and installed in different areas of interest, to have a seismic analysis of the whole operational field. Nevertheless, a survey of the seismic activity is only the first step. A PLI has the potential to become a feedback system, providing active stabilization to the orbit of an accelerator beam. This

could be done via fast change of magnet currents. If applied to other experimental setups, it could be used e.g. for moving actuators to stabilize a mirror/platform with micromovements compensating the passing seismic wave.

The priority in 2019 at CERN is the deployment of a seismic telescope with 5-6 devices to be able to reconstruct in real time the wave profile and the Earth surface deformation. The implementation of a larger system will give the possibility to explore the timing efficiency of the telescope and refine the feedback system capabilities to be compared with the requirements for the various applications.

The challenges presented in the open discussion session of the ATF 2018 regarded mainly the feedback system timing capabilities to turn the PLI in an active stabilizing system, exploiting the maximum frequency range. Mainly, two sub-challenges have been presented in detail. The first concerned the reaction speed and the frequency range of operation. A comparison to the demands of mirror stabilization in a GW detector brought to the observation that a fast orbit feedback system needed at the Large Hadron Collider (LHC) should work at the same frequency: 20-25 Hz. The second sub-challenge regarded the signal quality: how to filter the signal to avoid misfire and the question if machine-learning and artificial-neural-network approaches, as applied also in particle physics, are suitable to recognize and distinguish different kinds of seismic activities.

The audience dedicated to the analysis of these issues acknowledged that the PLI, with a precision of:

- $2.4 \times 10^{-11}$  rad/Hz<sup>1/2</sup> in the range [10<sup>-3</sup>, 12.4] Hz
- $10^{-9}$  rad/Hz<sup>1/2</sup> in the range [10<sup>-6</sup>, 10<sup>-3</sup>] Hz

outperforms any commercial inclinometer and has high potential as a seismometer.

The experts in this group invited the PLI team for specific common tests at their high-stability ex-

perimental facilities (e.g. the GINGER team and the INFN team working at VIRGO, the GW-detector in Italy). Parallel measurements by different setups in common runs e.g. VIRGO, GINGERINO, PLI, can improve the disentanglement of different contributions (angular rotations and linear drifts) of a seismic event. In addition, the experts from the Brussels School of Engineering of the Libre Université de Bruxelles, proposed a common test on a specialized mechanical platform. This platform is used in general to characterize the response of seismometers for GW-experiments with the aim of providing feedback for stabilization of the mirrors and the platform itself. This step allows for a characterization with respect to rotation and translation in order to study both components of the movements. The VIRGO experts asked if the PLI team could provide an estimation of the precision of measurements at 10 mHz. The benchmark figure for such a precision, which would be of great help for VIRGO mirror stabilization, is 10<sup>-8</sup> rad/Hz<sup>1/2</sup>. As aforementioned, the PLI has a better precision than this by a factor of 10.

Specialists in electronics for readout, feedback and feed-forward indicated that possibly a feed-forward system is the best one to be adopted for the PLI. Experts from Lancaster University suggested the use of fast Texas Instruments Ethernet Microcontrollers that would facilitate the use of an array of PLIs to be used as a seismic telescope.

Among other suggestions, there was the possible use of a large mass to be placed in proximity of a PLI to measure the gravitational attraction of such a mass and evaluate the attainable precision. It was stressed that the PLI team needs to better define the reference with respect to which they perform measurements. It was a consensus that it is difficult to compare the PLI to any available instrument as the precision reached is out of range even for well-known and expensive seis-

ometers.

After following these suggestions and future enhancements in the mHz frequency range, the precision of the PLI can even further improve and be potentially appealing to experimental facilities in need of stabilization systems.

### @MADMAX

Another topic that in parallel was deeply discussed by another set of experts was the challenge for the production of tiled large-area dielectric disks and their precise positioning in the MADMAX experiment.

For the adopted dielectric haloscope approach in the search of dark-matter axions, thin dielectric disks will be aligned and positioned inside a strong magnetic field. The specific requirements are listed at page 21.

The main sub-challenges were two. The first concerned the production of large-area tiled disks. The MADMAX team asked for suggestions concerning how to:

- precisely (laser-) cut the hexagonal tiles from LaAlO<sub>3</sub> wafers,
- automate the positioning and alignment of tiles on custom jig,
- automate a precise dispensing of 2K epoxy glue in the gaps between tiles,
- precisely treat/polish the tiled disk surfaces,
- characterize the microwave properties of tiled disks at cryogenic temperatures.

The time left to find the best solutions to these issues for the prototype version of the experiment (featuring 20 disks with 30 cm diameter) was 6 months.

The second sub-challenge concerned the positioning and alignment of the disks. For this, the MADMAX team was mainly concerned by how to:

- precisely position the disks at ±10 μm at maximum travel of 2 m,
- measure the disk positions and tilts to

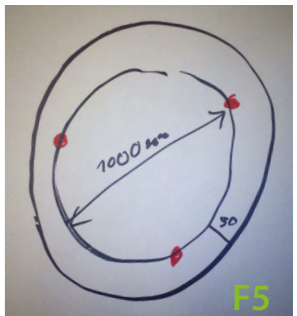
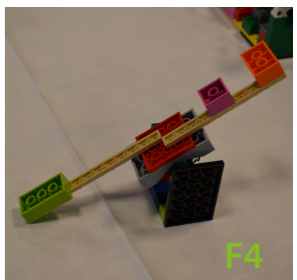
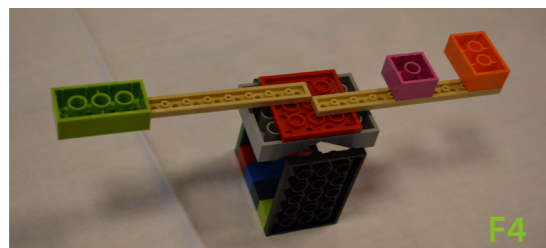
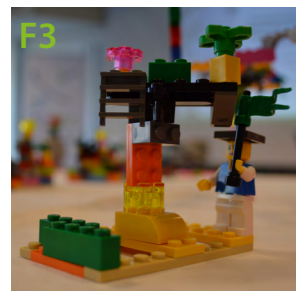
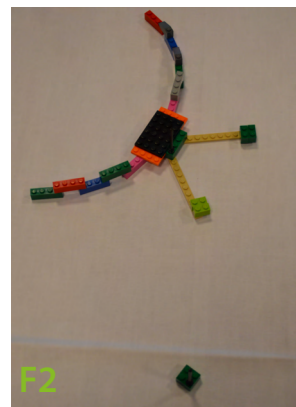

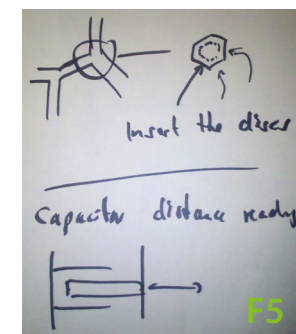
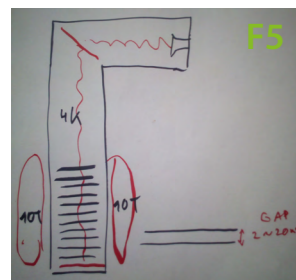
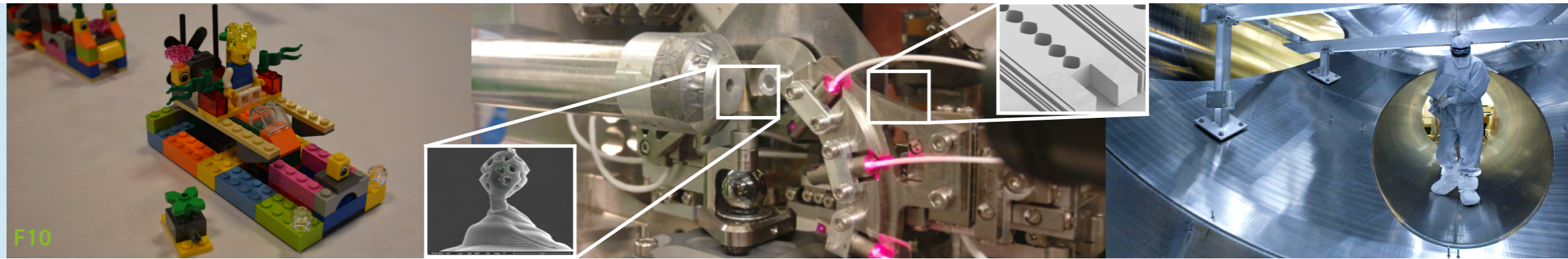

- 10  $\mu\text{m}/4$  arcsec accuracy,
- find drive and positioning systems working at 4 K in high vacuum,
- find positioning systems working inside a 10 T magnetic field,
- define an algorithm to identify the correct disk spacings based on the measurement of a single microwave quantity.

This second group of issues has a more relaxed time schedule, and the deadlines for finding feasible solutions are 1 year and 2 to 3 years for the prototype and the full-size MADMAX experiment, respectively.

In comparison to the other two experiments under discussion, the present demands of the MADMAX team tackle multiple R&D aspects where still different applicable techniques and strategies are viable. This situation attracted the interest of young researchers dealing with similar issues in experiments with a comparable background and company experts devoted to the search for the best engineering solutions for their customers. Two widely shared opinions emerged and the relative suggestions were made to the MADMAX team. Concerning the construction of the setup, it is important to concentrate the efforts in finding efficient ways to extend at maximum the area of the tiles composing the disks. The application of the chosen material  $\text{LaAlO}_3$  in large single structures has at present technical limitations, but even if there is a suitable choice of different glues, the amount of it used to connect the tiles should be reduced to minimum, because the tile connection represents one of the weaknesses of the disk. Technical advice for this purpose was to design tiles without straight edges, but rather with tapered boundaries, reducing the needed amount of glue. Furthermore, in an ideal case, the tiles could be mounted in a grid and rimmed at the edges, to be stabilized in an ultimate glue-less solution. The second shared recommendation re-

garded the positioning and active stabilization of the disks. This is one of the most challenging operations for the experiment and the MADMAX team proposed the installation of a complex system of a very high number of laser interferometers (sixty, three each disk in the prototype). The audience suggested to be cautious with such a system, that would be very hard to align and possibly troublesome during routine measurements. From the ALPS team, two more specific proposals about the manufacturing and the stabilization of the MADMAX setup, respectively were presented. For the construction of the tiled disks, a photolithographic process has been suggested. Compatibly to the physical and chemical properties of  $\text{LaAlO}_3$ , the ceramic wafer covered by a photoresist could be exposed to a suitable light source and then developed. In order to be adequately designed, different patterns could be used and a shutter could be introduced, if periodic structures have to be precisely defined. Consequently, the etching process could be applied. For ceramic wafers, a suitable IPS ceramic etching gel has been recommended. Considering that the application of laser cutting has been discouraged in presence of photosensitive material, other cutting procedures, such as waterjet-based techniques have been suggested.

For the positioning and the stabilization of the



disks, the MADMAX group was still very open to new ideas. This included an analysis of fundamental physical principals that can be newly applied in a possible future facility. An important factor is the definition of a measuring technique for the positioning of the disks. This can be done considering at least three points on each disk and, depending on the precision requirements still to be evaluated, with the angle of inclination of each one with respect to the other disks. How to implement such a system is still an open question. An option would be a laser-based method, implying e.g. the detection of the reflected beam from three spots on the rear side of the front surface of the disks, reached by drilling from the back. Presently, the MADMAX team is testing the application of retroreflectors to the disks as viable solution to simplify the alignment procedure. A common suggestion from the audience was to first dedicate enough time into calculating and simulating the exact requirements of the setup, based on the precision with which the axion mass has to be measured. Other parameters, such as the constituting material and the thickness of the disks are not 100% defined, yet and there are chances that a full tracking system for the disks is not necessary or much simpler ones than those already introduced can be applied.

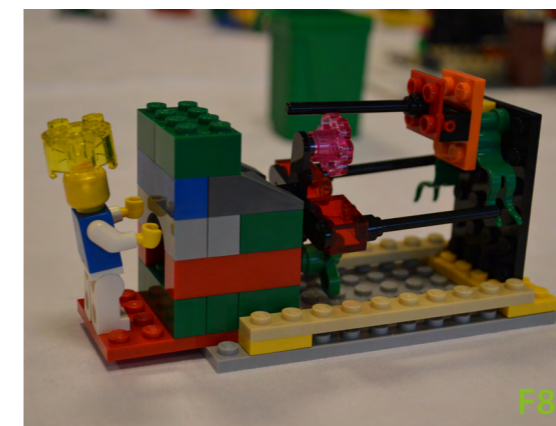

**@European XFEL**

The last topics that were discussed by a third group of experts were the challenges encountered by the representatives of European XFEL in the development of their photon beam transport. The quality of optics has been improving at tremendous rate in the past years and now every kind of imperfection or instability in the mechanics has an impact on the final beam quality, if the mechanical elements do not have the same quality level of the optics surface. This means that for every device involved in the beam transport there are different sub-challenges to be faced. From the technical point of view, the measurement of optics at nm-level and of their performance in the beamline is still demanding. Especially the disentanglement of different effects such as mechanical vibrations, thermal effects and the stability of the source is problematic. From the organizational point of view, how to effectively approach the vendors is still an open question. The definition of specifications, for example including simulations and a market research in advance of the needed device, is not always the way to go for. Furthermore, in the most complex cases, the possibility to collaborate with a company, sharing a R&D program for the improvement of the performances is often difficult to realize and demanding in terms of time and resources from both sides. A few companies participating at the ATF 2018 are used to such kind of collaborations with scientists and could describe how they routinely interact with customers having shared on-going development projects. For example, an IT and legal strategy has to be established and followed to protect sensitive data. Additionally, the industry partners typically suggest to customers to clearly separate the specifications of the desired product from a possible solution to the related challenges, they might have already thought about. This helps in the unequivocal definition of the tasks and favors

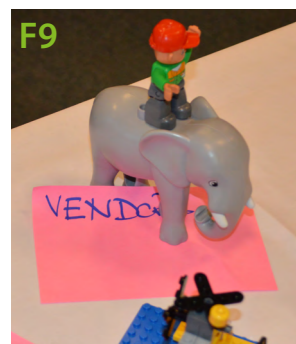
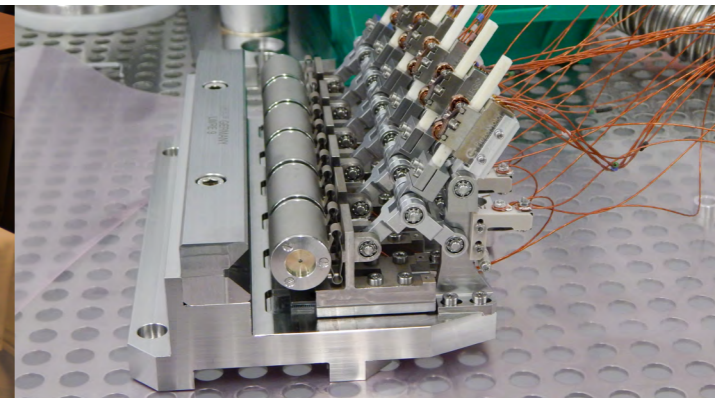

an effective collaboration.

Considering the kind of challenges presented by the European XFEL team, mostly experienced optics experts and participants from different companies belonged to the dedicated audience. The approach of research to industry was the topic that was mostly analyzed. Clearly, there is not a univocal solution, but all the different actors playing a role in the interaction have been considered and a strategy to improve the communication has been sketched. The identified different elements and people involved in the process were:

- device/product to be purchased,
- relative specifications,
- experimental setup needing the device,
- engineer/s working on the experiment,
- physicist/s working on the experiment,
- procurement division,
- vendor/s.

Six out of seven actors belong to one side of the transaction, i.e. difficulties of communications are primarily on the research side, especially in large facilities. The first issues emerge already in the interaction between the physicist and the engineer: challenging but still achievable specifications have to be set by the physicists and an open-minded approach has to be followed by the engineer/s. If it is decided that it is necessary to contact an external vendor, usually many iterations on the decision of the specifications are occurring between the two. Typically, the physicist is in charge for the first draft of the whole setup and the specifications of the included devices. Then, he discusses them with the engineer, who has generally a good overview of the capabilities inside the facility and in industry. A convenient way to proceed, would be to recognize the respective expertise and roles in the institution. In this way, the number of iterations would be reduced. Once the specifications are agreed, the procurement department can be contacted. Un-

fortunately, this necessary step is time consuming and it has to be considered during the project scheduling. If the device to be purchased is particularly expensive, by law many vendors have to be contacted and the best offer has to be awarded, neglecting in extreme cases the previous common effort to define and shape the technical specifications. An acceleration to the technical waiting times would be given if the procurement could be more sensitive to the R&D demands and already involved i.e. during the early discussions between physicists and engineers. When an ideal vendor has not yet been identified, the procedure can undergo a further delay. This is often the case when the device to be purchased has extraordinary specifications and the vendor has to agree in supporting science, at least partially, with his/her own R&D budget. This phase involves possible future industry partners and a series of negotiations. Many companies do not see the profit if the product is too specialized. This can have the effect of a prolongation of negotiations concluding without a fruitful deal. Also in this case, a more solid support from the procurement department could reduce all these efforts. Possibly, the solution is the introduction of a new figure, similar to an industry liaison officer, but more dedicated to the singular demands of the experimental setups in large facilities. He/she would have a deeper technical and legal understanding and be able to professionally overtake the negotiations with the vendors, saving the time of experimentalists and



procurement employees. This new actor could be responsible not only at the moment of the engagement of a company, but also be the contact person during the development of the project. Notoriously, specifications very often change with time and the parallel evolution of the facility and its applications. This can cause dramatic delays or even a failure if not properly communicated to the vendor. A periodic update of the status of the development and the demands from each side could be accomplished by this new figure. Thanks to the discussions among optic experts, the ATF 2018 led to a fruitful collaboration between the ALPS and European XFEL teams. The first has the opportunity to measure the micro-roughness of their mirrors and pursue further characterizations with very precise interferometers placed at European XFEL. This is helping the ALPS team in identifying the origin of losses through scattered light like never done before.

### The APPEC Technology Forum 2018: what's next?

The structure of the ATF 2018 was diverse, including standard talks, but also an open brainstorming session, a hands-on exhibition and a company fair. This gave in different ways opportunity to all the participants to interact with each other, independently from their scientific or technical background. Fruitful collaborations were initiated during the forum and will be pursued in the future. Some emerging technologies with unexpected level of sensitivity could be presented to different communities. Manifold experiences could offer scientific and technical support to young large experiments. Exclusive machineries were placed at the disposal of colleagues for precise measurements and interdisciplinary comparison.

After the positive outcome of the ATF 2018, the motivation to further organize such events is

### The APPEC Technology Forum 2018: comments and feedbacks

***"Finally an event different from the others, where problems are openly discussed"***

H. Janssen  
JPE

***"A nice opportunity to talk to people from other fields and for possible new collaborations"***

B. Di Girolamo  
CERN



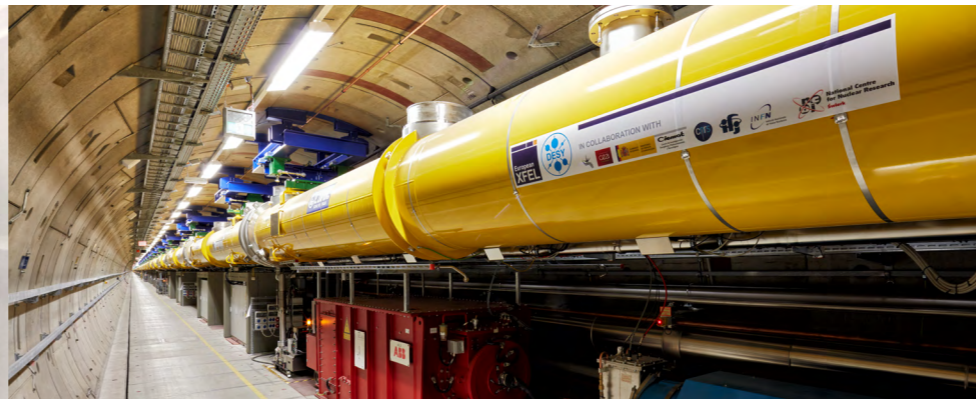
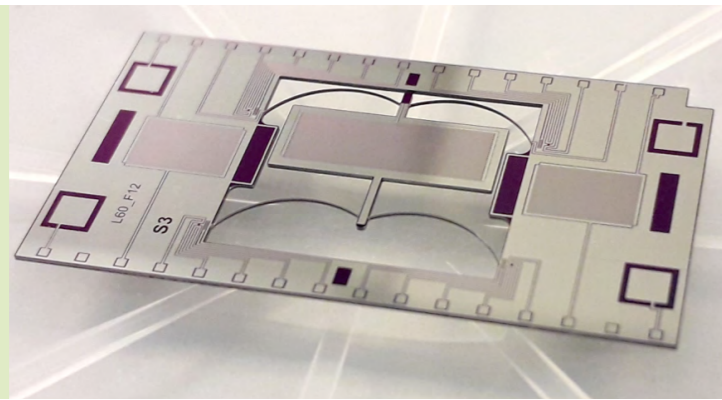

## Scientific topics

10

### Precision for the KATRIN experiment

- 12 Gas injection system for ultra-stable pressure and composition of the KATRIN source
- 13 Temperature calibration and stabilization in strong magnetic fields of the KATRIN source
- 14 Precision stabilization of high voltage in the KATRIN electrostatic spectrometer
- 15 Long-term stabilization and voltage reference at KATRIN

### Seismic isolation for GW-detection & more

- 16 The advanced Virgo Superattenuator for Virgo
- 17 Development of an active seismic isolation stage for high-precision active-isolation projects
- 18 Ultrasensitive MEMS gravimeters for aLIGO and more
- 19 Dynamic wave-tracking for physics and applications

### Seismic isolation for particle physics

- 20 Seismic environment and control strategy for ALPS II
- 21 Production of tiled large area dielectric discs and precise disc positioning for MADMAX
- 22 High-precision seismic measurements for CERN/JINR collaboration

### Precision for general relativity and photon science

- 23 Application in seismology and geophysics of GINGER
- 24 Metrology, engineering and installation challenges at European XFEL

11

# Gas injection system for ultra-stable pressure and composition

## General

Neutrinos are by far the lightest particles in the Universe. According to the Standard Model of Particle Physics neutrinos should be massless. However, the existence of their mass has been proven experimentally by the observation of neutrino mass oscillations.

The Karlsruhe Tritium Neutrino (KATRIN) experiment at the Karlsruhe Institute of Technology aims for a direct neutrino mass determination with a sensitivity of 200 meV/c<sup>2</sup> (90% C.L.).

The measurement will be performed by precise spectroscopy of the tritium-β-decay electrons near the kinematic endpoint of 18.6 keV.

That is achieved by employing a high-resolution ( $\Delta E < 1$  eV) MAC-E-type high-pass energy filter coupled to a high-luminosity (10<sup>11</sup> Bq) windowless gaseous tritium source which is supplied by the closed gas processing loop of the Tritium Laboratory Karlsruhe (TLK) at throughput of 40 g of T<sub>2</sub> per day.

The source stability (activity, gas density, composition) is required to be better than 0.1% to achieve the neutrino mass sensitivity.

In his presentation, **Magnus Schlösser** gave an introduction to the tritium loops of KATRIN at the Tritium Laboratory Karlsruhe. The major technical aspects of the realization of an ultra-stable injection of tritium gas and of the gas composition stabilization was discussed. Additionally, the compositional monitoring by a custom-built Laser Raman System was explained.

Finally, the performance of the gas injection during the first tritium campaign as well as its impact on the global KATRIN measurement stability was presented.

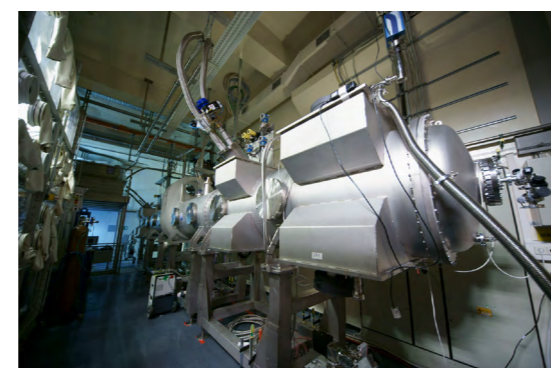
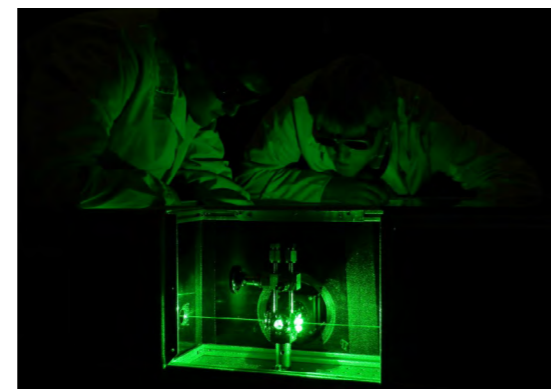

# Temperature calibration and stabilization in strong magnetic fields

## General

One of the most significant systematic uncertainties of KATRIN is the temperature of the tritium source. The source is a 10 m long vacuum tube in the bore of superconducting solenoids, designed to operate at 3.6 T. It is equipped with a dedicated temperature stabilization system, which keeps the temperature stable on a low mK-level. For the absolute temperature calibration, at 30 K, a proprietary vapor pressure calibration system is used.

The talk of **Alexander Jansen** gave an overview of the KATRIN source cryostat, with the focus on its temperature calibration and stabilization system, and it summarized the long-term operation.

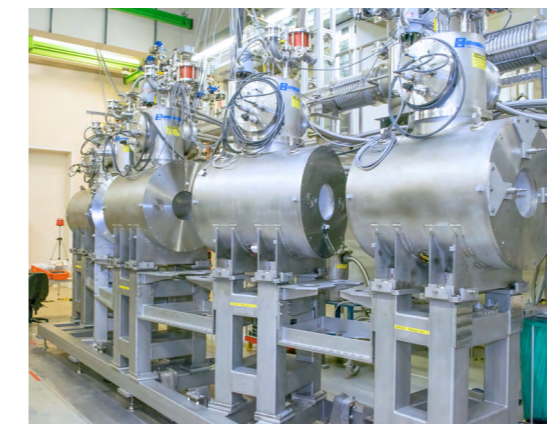
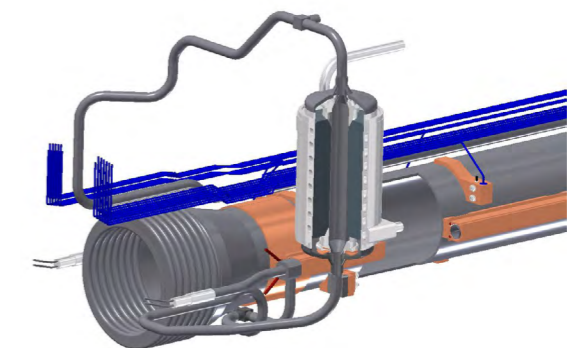
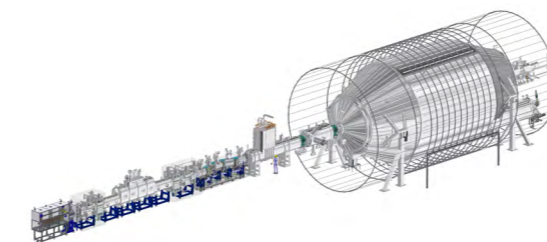

# Precision stabilization of high voltage

## General

In the KATRIN neutrino mass experiment, the energy distribution of Tritium beta electrons is measured at an unprecedented precision. This is done with an electrostatic retardation spectrometer in a MAC-E filter configuration, consisting of an ultra-high vacuum vessel with a diameter of 10 m and with a length of 23.3 m. The retardation voltage applied to the vessel is at about 18.6 kV in normal operation, but up to 33 kV in calibration modes. The precision of this voltage must be in the ppm-range (20 mV).

Due to the unshielded vessel, but also through other causes, there is a number of interference sources.

In his presentation, **Sascha Wüstling** showed the methods used to obtain the required accuracy on time scales from the  $\mu$ s range up to the long-term stability.

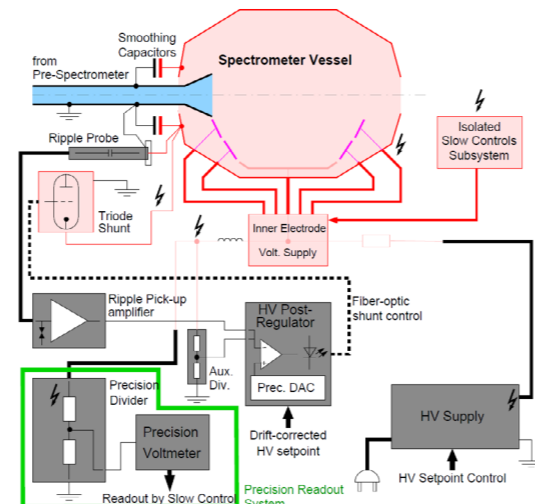

# Long-term stabilization and voltage reference

## General

At KATRIN the retarding potential of the main spectrometer will be measured directly via two custom made ppm-precision high-voltage (HV) dividers, which were developed in cooperation with the German national metrology center PTB. In order to determine the absolute values and the stability of the scale factors of the voltage dividers, regular calibration measurements with ppm precision are essential. To guarantee a redundant monitoring system two independent HV calibration methods are used: electrical calibrations with different reference HV dividers showed sub-ppm-stability of the scale factors over the last years.

In addition to that, the HV will be compared to a natural standard given by mono-energetic conversion electrons from the decay of Kr-83m. This is done with three independent sources (implanted, condensed and gaseous) distributed over different locations of the experiment.

The talk of **Oliver Rest** gave an overview of the HV calibration of the KATRIN experiment and showed a summary of the calibration measurements over the last years.

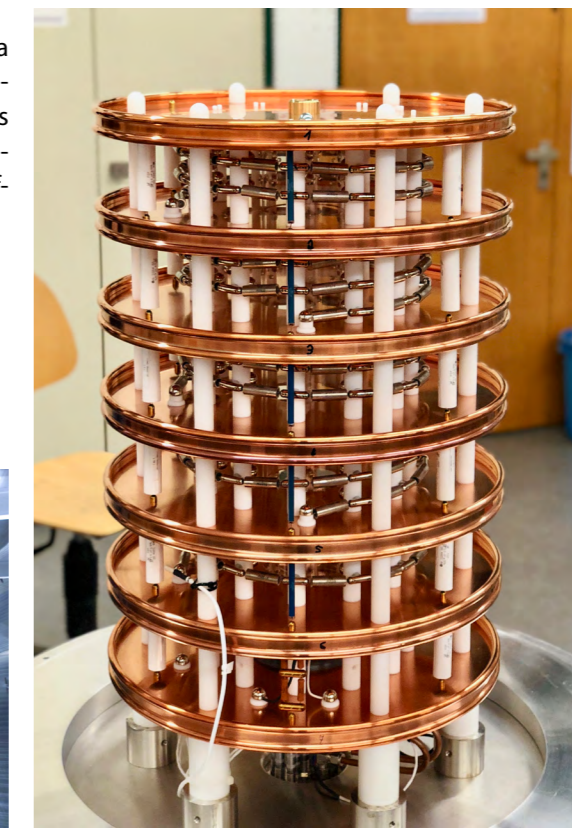



# The advanced Virgo Superattenuator

## General

In the last two decades a big effort has been done in the conceptual design and construction of the modern ground based interferometric detectors for gravitational-wave observation. A further jump in forward direction was done with the introduction, in the experimental apparatus, of complex mechanical structures filtering seismic noise and local disturbances with the intent to extend the detection bandwidth in the low frequency region (below 100 Hz) where many astrophysical sources are expected to emit mainly low frequency gravitational waves. To this purpose the second-generation interferometers have been equipped with mechanical structures based on the working principle of a multi-stage pendulum to overcome the most limiting factor, in the low frequency region, represented by seismic noise. An important pioneering activity in this field was carried out by the INFN Pisa Group involved in the construction of the Virgo detector for which a complex structure, called Superattenuator, has been developed as suspension system to filter seismic noise down to the optical components.

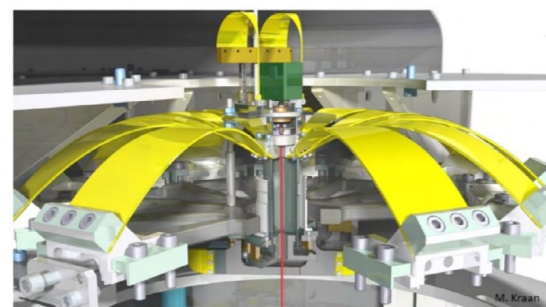

In his talk, **Franco Frasconi** presented an overview of the techniques developed in the contest of gravitational-wave research, emphasizing the importance of these mechanical structures for the 3<sup>rd</sup> Generation interferometric detectors. The description of the main elements of the Superattenuator together with the technological solution adopted to fulfill the requirements of the second-generation interferometers, Advanced Virgo, was presented. A quick comparison between two different methods to create an anti-spring effect on board of each pendulum stage along the suspension chain was described, too.

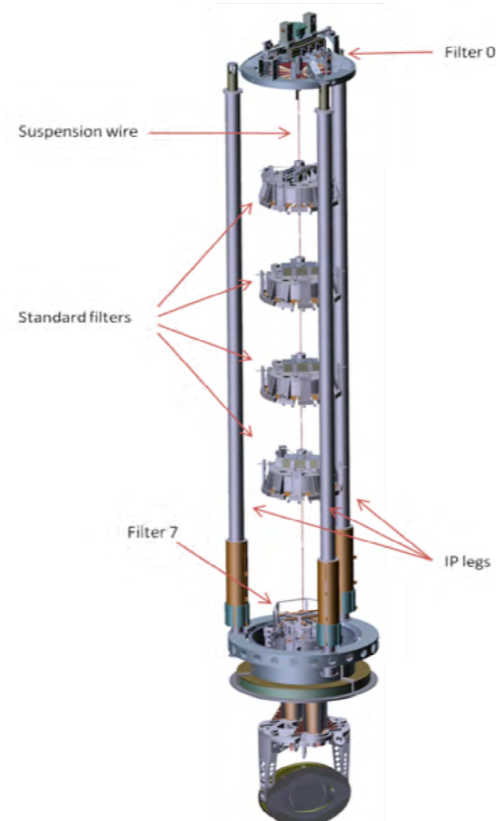

# Development of an active seismic isolation stage

## General

At the Precision Mechatronics Laboratory, they are working on the development of a new active isolation system which fulfills the high-performance criteria in the low frequency domain (from 10 mHz to 10 Hz). To reach the requirements, a high-resolution optical inertial sensor is currently under development. It combines good mechanical properties of a STS-1V seismometer with a low-noise interferometric readout. The sensor is insensitive to magnetic fields as it does not contain any coil or magnet. The sensor has a resolution of  $10^{-13}$  m/Hz<sup>1/2</sup> at 1 Hz. The ability to isolate actively a platform with this sensor has already been demonstrated in the vertical direction. The transmission of vibrations from the ground to the structure has been attenuated by at least a factor 100 between 10 mHz and 10 Hz.

In his talk, **Christophe Collette** explained in details the working principle of the sensor and its performance. Also, an isolation project with the sensor was introduced.

## Requirements:

- Optical inertial sensor with
  - Low thermal noise
  - Low resonance frequency
  - High quality optics
- Versatile active isolation system with
  - Good architecture that reduces coupling between directions
  - Robust controller
  - Low noise instrumentation
  - Performance between 10 mHz and 10 Hz

## Applications:

- Atom gravimetry
- Gravitational-wave detectors
- Lithography
- Medical imaging

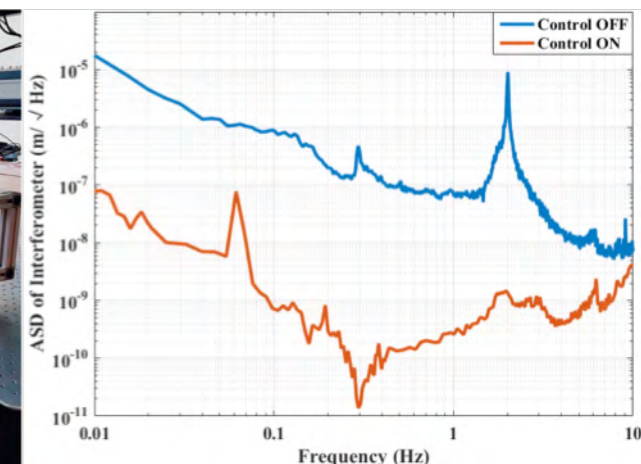
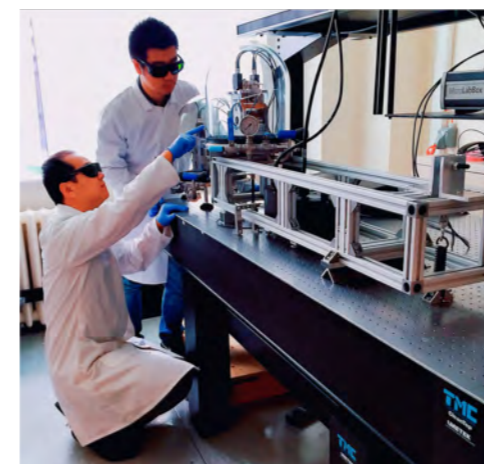

# Ultrasensitive MEMS gravimeters

## General

Researchers at the Institute for Gravitational Research, University of Glasgow have been developing an ultrasensitive MEMS (micro electro mechanical systems) accelerometer technology. The research team, who also developed/installed/commissioned the fused silica suspensions used in the Advanced Laser Interferometer Gravitational-Wave Observatory (aLIGO), have used their expertise in precision opto-mechanical experiments to develop the first MEMS gravimeter. The device has sufficient sensitivity to measure the Earth tides; elastic deformations in the Earth's surface due to the tidal potential of the Moon and Sun. This is a transformative technology, allowing small-cheap MEMS devices to be used in a variety of application areas.

In his talk, **Giles Hammond** described the development of the MEMS gravimeter. The device is fabricated in the James Watt Nanofabrication Centre and utilizes a patented geometrical anti-spring flexure technology to provide enhanced sensitivity. The device weighs less than 0.5 kg, runs off battery power and can be deployed in the field to perform both seismic and gravitational monitoring. The team is currently engaged in a FET-OPEN project to deploy 50 devices onto Mt. Etna by 2020. This will be the first multipixel gravity imager, capable of monitoring/imaging the magma build-up in volcanoes.

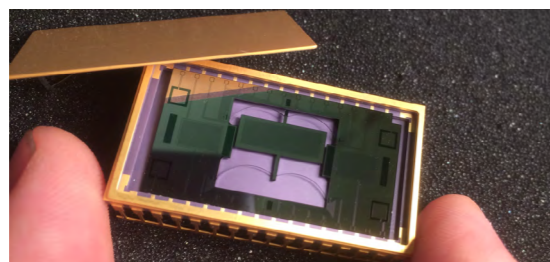

## Requirements:

- Sensitivity of better than 10  $\mu\text{Gal}$  (1 Gal = 1cm/s<sup>2</sup>)
- Temperature control at the level of 1 mK over several days
- Tilt control at the level of 5  $\mu\text{rad}$
- Deep Reactive Ion Etching of silicon wafers and metallization to produce on-chip thermometers and electrodes
- FPGA readout for the accelerometer
- Vacuum packaging

## Applications:

- Gravitational-wave detectors
- Oil & gas exploration and well monitoring
- Defense & security
- Navigation and environmental monitoring.

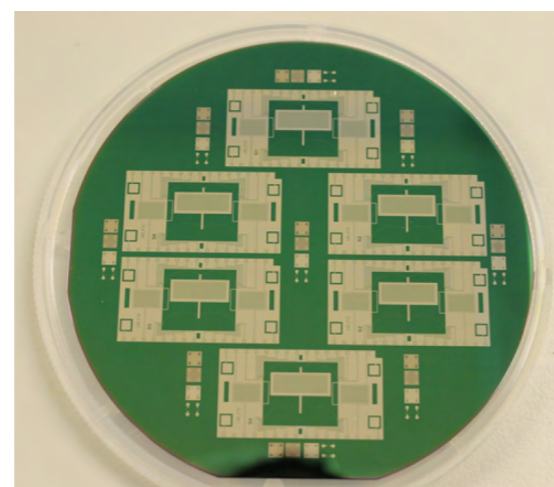

# Dynamic wave-tracking

## General

A common problem in precision measurement is the ability to dynamically track waves data streams that also contain other waves at different frequencies and broadband background noise. Development of adaptive filters that behave somewhat like lock-in amplifiers, but have some key advantages over the traditional approach to this problem, has taken place in the context of signal processing for gravitational-wave data analysis.

In his talk, **Edward Daw** gave an overview of his research in the different areas of application of dynamic wave-tracking.

## Applications:

- Fundamental physics:
  - gravitational-wave data analysis
  - searches for hidden sector dark matter
  - quantum measurements
- Measurement and control problems in industry (by now early stages of application)
  - control of electric motors
  - acquisition and analysis of data from multi-channel magnetocardiographs
  - development of novel communications protocols for software-defined radio.

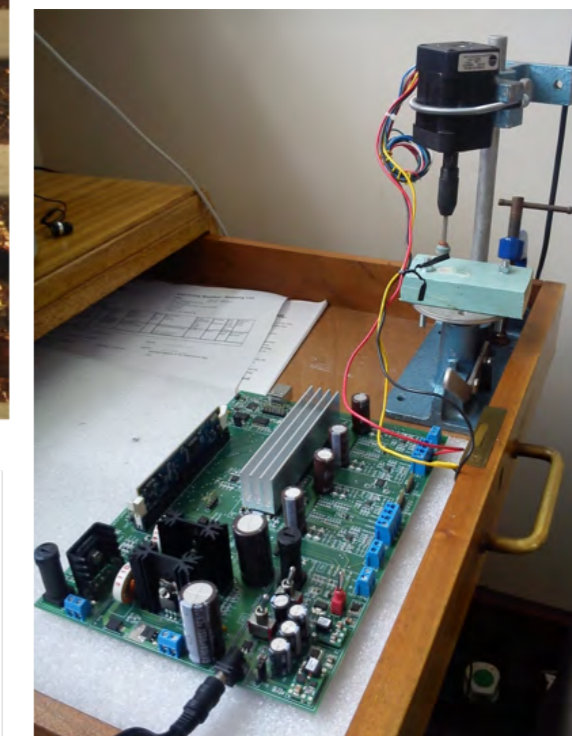
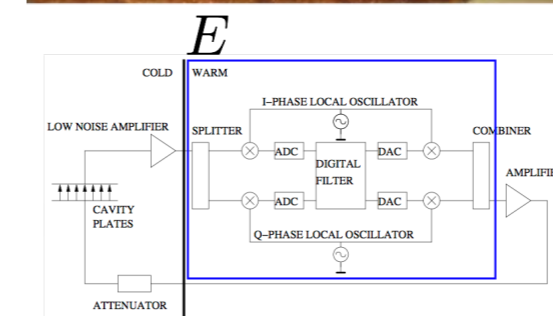
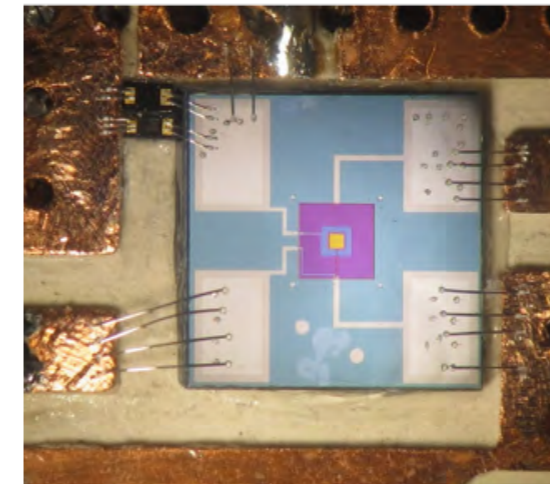

# Seismic environment and control strategy

### General

ALPS II is a light-shining-through-a-wall experiment searching for undiscovered sub-eV elementary particles motivated by astrophysics and cosmology. These particles are not accessible with accelerator-based experiments.

ALPS II will be based at DESY in Hamburg. It uses 20 superconducting HERA dipole magnets, ultra-stable lasers and two long-baseline cavities that are housed in a 200 m long vacuum system. To enhance the sensitivity of the experiment the light circulating in the first cavity needs to be simultaneously resonant in the second cavity.

As seismic noise is one of the main noise sources, the environmental conditions were surveyed and a sophisticated control scheme is currently being designed.

**Dominik Miller** and **Jan H. Pöld** provided an overview of the ALPS II control scheme and discussed the seismic noise measurements from the experimental site.

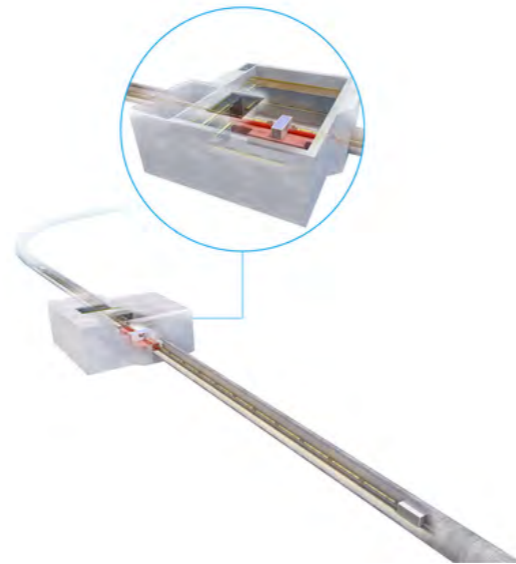

# Production of tiled large-area dielectric disks and precise disk positioning

### General

The MADMAX experiment will search for dark matter axions applying the dielectric haloscope approach to cover the theoretically very well motivated but previously inaccessible axion mass range (40 to 400  $\mu\text{eV}$ ).

For this  $\sim 80$  thin dielectric disks with an area of  $\sim 1\text{m}^2$  will be used and then have to be aligned and positioned inside a  $\sim 9\text{ T}$  magnetic field at cryogenic temperatures and under high-vacuum conditions with spacings of 2 to 20 mm and a required precision of  $\sim 10\ \mu\text{m}$ . As  $\text{LaAlO}_3$ , the preferred material for the disks, is currently only available in a wafer size of at maximum 2", the large disks need to be glued from small hexagonal tiles.

As an intermediate step, a prototype setup is under development featuring 20 disks with 30 cm diameter to study the drive system for the positioning of the disks as well as the tiled disc production.

In his talk, **Christoph Krieger** presented the current plans and first results for the production of 30 cm dielectric disks made from  $\text{LaAlO}_3$  tiles as well as the preliminary design of the disk positioning mechanics and drives for the MADMAX prototype system.

### Requirements:

- Positioning and alignment of disks in MADMAX:
  - positioning precision of  $\sim 10\ \mu\text{m}$  at maximum travel of 2 m
  - knowledge of disk positions and tilts to  $10\ \mu\text{m} / 4\ \text{arcsec}$  accuracy
  - drive system and position determination working at 4 K in high vacuum
  - positioning system functional inside 10 T magnetic field
  - algorithm to find correct disk spacings based on the measurement of a single microwave quantity
- Production of large area tiled disks:
  - precise (laser) cutting of hexagonal tiles from  $\text{LaAlO}_3$  wafers
  - automated positioning and alignment of tiles on custom jig
  - automated and precise dispensing of 2K epoxy in the gaps between tiles
  - precision treatment/polishing of tiled disk surfaces
  - characterization of microwave properties of tiled disks at cryogenic temperatures.

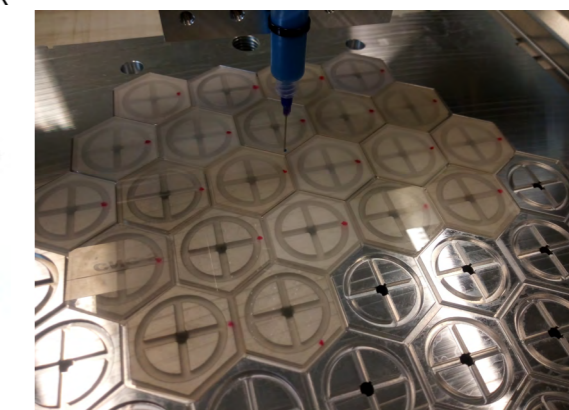
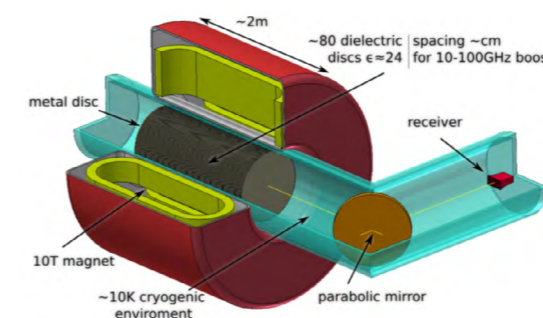

# High-precision seismic measurements

## General

CERN and JINR are collaborating for the further development of a novel instrument, the Precision Laser Inclinator (PLI), originally conceived at JINR as part of a set of very high precision metrology instrumentation based on laser deployment. The initial collaboration within the ATLAS experiment, for the accurate measurement of the experimental cavern stability, has evolved in developing techniques to monitor and provide feedback to multi-TeV colliders in presence of natural and human-originated seismic events.

The impact of seismic events on colliding beams has been studied in the past and it will become more and more problematic for multi-TeV present and future colliders, especially for  $e^+e^-$  operations. Studies with single PLI devices and for upcoming multiple PLI-based seismic telescope show the need of stabilization systems.

In his talk, **Beniamino Di Girolamo** presented the general working principles of the PLI, the obtained results in terms of resolution in angle measurements and the measurements of the impact of local and far earthquakes on the LHC collider beams. The studies of impact of seismic events on future colliders were presented along with the possible usage of the PLI devices to implement alerting and feedback systems for stabilization. A view on other possible applications and on the potential societal aspects of the PLI instrument were presented.

## Requirements:

- Development of more sophisticated analysis techniques for fast feedback
- Time and frequency domain signal reconstruction
- High precision readout and stability
- Extension of the frequency range for precision measurements
- Development of signal combination for multi-device seismic networks

## Applications:

- The PLI is a general-purpose instrument and can be used as input to stabilization of any research infrastructure.

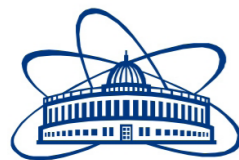
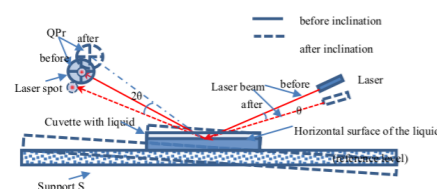
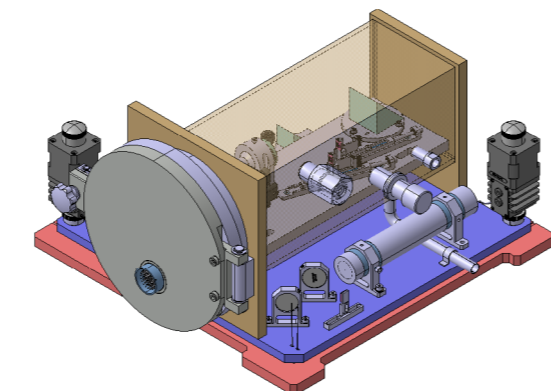
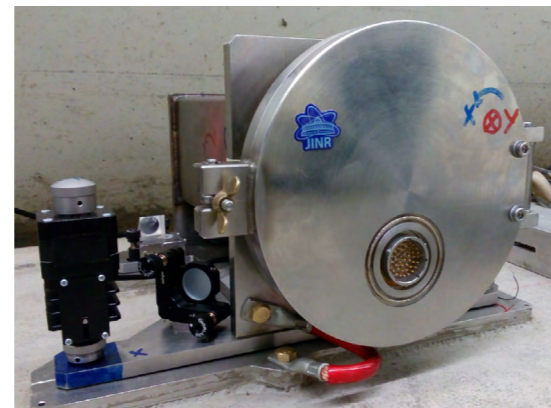

# Application in seismology and geophysics

## General

Large frame ring laser gyroscopes (RLG), which exploit the Sagnac effect, are the most sensitive device for detecting absolute angular motions in an Earth based apparatus. Sensitivity much below fractions of  $\mu\text{rad/s}$  have been already proved. GINGER is an INFN project to build a large-frame 3-dimensional array of RLG inside the underground Gran Sasso Laboratory (LGNS), 1000 m underground, far from surface perturbations, with the final aim of measuring at the latitude of Gran Sasso the Lense-Thirring effect with 1% relative precision. A first RL will be oriented parallel to the Earth rotation axis, i.e. in the direction for which the Sagnac frequency has a maximum. This is one of the few tests of General Relativity feasible on Earth.

In her talk, **Angela Di Virgilio** outlined the main scheme of GINGER, and the status of GINGERINO, the RLG prototype operative inside LNGS since 2014. The analysis of GINGERINO and its application to Seismology and Geophysics were reported. In seismology translation and strain are routinely observed by seismometer and strain meters. However, a full description of the ground movement requires also the acquisition of a third type of measurement, namely rotations. Co-located translation and rotation observables allow to estimate the local velocity structure, which is of high interest in geophysical prospections. Rotational signals induced by seismic waves have a quite small amplitude. A strong seismic wave with a linear acceleration of  $1 \text{ mm/s}^2$  produces a rotation velocity amplitude of some  $10^{-7} \text{ rad/s}$ , while microseismic (around 0.1 Hz) rotational background noise is expected to be smaller than  $10^{-10} \text{ rad/s}$ . Large frame RLGs have demonstrated an unrivaled sensitivity level. The sensitivity of RLGs of smaller size was shortly described.

## Requirements:

- Relative accuracy at least of the order of  $10^{-10}$ - $10^{-12}$  of the Earth rotation rate, i.e. smaller than a few  $10^{-14} \text{ rad/s}$ .
- At least 3 RLGs, with different orientation, will be necessary to recover in amplitude and direction any kind of variation.

## Applications:

- GINGER is highly multidisciplinary:
  - data for geophysics and geodesy
  - it can record any tiny variation of the Earth crust and the sub-daily variations of the polar motion and of the length of the day.

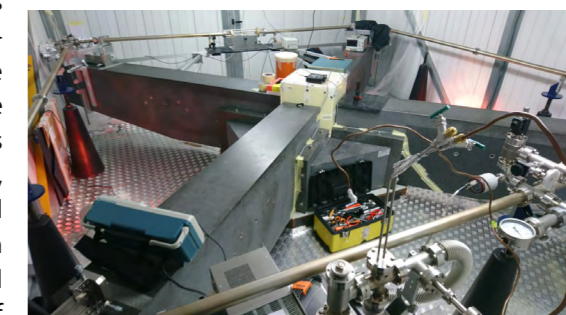
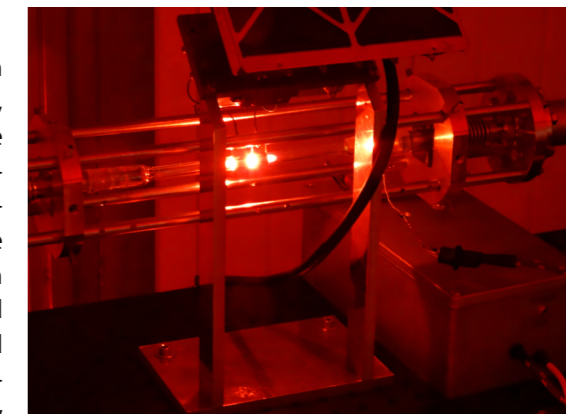

# Engineering challenges for the photon beam transport

## General

European XFEL, the Free-Electron-Laser facility in Hamburg (Germany), started user operation in September 2017.

The novel facility produces at MHz repetition rate, coherent, 1 mJ energy, femto-second pulses in a photon energy range that spans from 0.3 to 25 keV. The facility comprises of a linear accelerator and three beamlines: SASE1 works in the hard X-ray regime and it is presently in user operation; SASE3 is the soft X-ray beamline and it is in advanced commissioning with beam and ready to receive users by the end of 2018; SASE2 is the second hard X-ray beamline that saw FEL light in early May 2018 and it is now in beam commissioning phase.

In his talk, **Daniele La Civita** presented the interesting and new engineering design challenges caused by the extraordinary length of the beamlines together with the high energy and high repetition rate pulses.

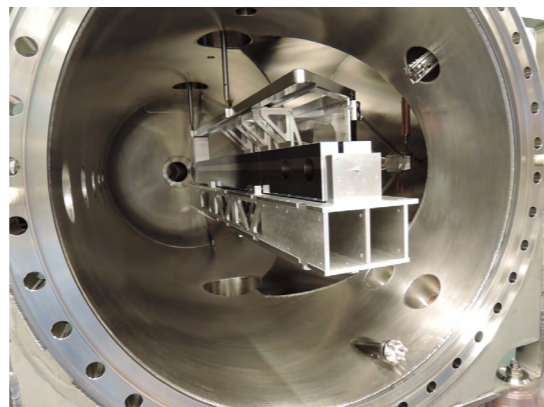
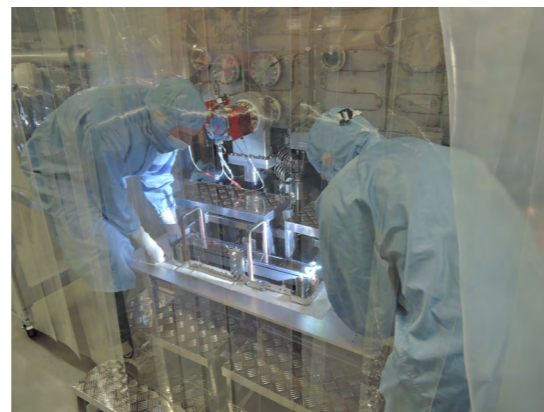
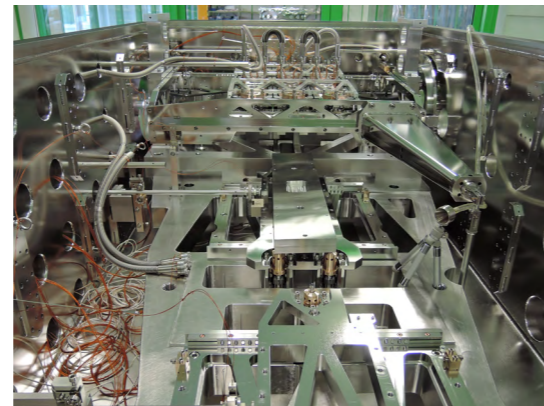

# Metrology and installation challenges

## General

All the major synchrotron radiation facilities around the world have recently started upgrade projects to go towards the 4<sup>th</sup> generation of x-ray sources (DLSRs) in order to produce photon beams with better quality. Several FELs, also providing diffraction limited beam, are operating and increasing their performances, while other ones are close to be operational or in planning. To fully exploit the ultimate source properties of these next-generation light sources, optical components like x-ray mirrors need to have shape accuracies in the nanometer regime over macroscopic length scales up to 1 meter. The ratio between these two quantities poses new challenges to optical metrology, installation and commissioning of such systems, and this became recently well represented in the case of European XFEL.

In his talk, **Maurizio Vannoni** described the main metrology and installation challenges involving the nanometer-level precise optics for European XFEL and new issues and solutions for the consequent need of better and more precise optical and mechanical systems.

## Requirements:

- Long mirrors (meter range)
- High optical quality (50 nrad RMS slope error in the 1-10 mm frequency range)
- Thermal grounding (10 W thermal dissipation).

## Challenges:

- Preservation of the outstanding optical quality after mounting of the optics and under variable thermal loads.
- Design of stable mechanics that match the optical quality of the mirrors.

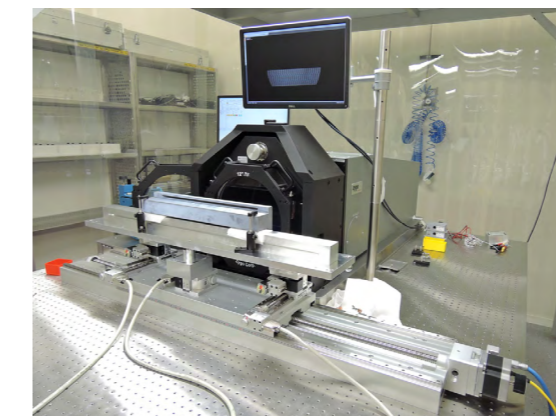

- 27 FMB Oxford
- 28 Galli e Morelli
- 29 Innoseis
- 30 JPE
- 31 SmarAct
- 32 VDL Enabling Technologies Group

## FMB Oxford

FMB Oxford is a leader in the supply of beamlines and beamline components to the scientific community, specializing in the design, assembly, test, installation and commissioning of the high value systems.

With over 20 years' experience in the synchrotron and FEL industries, FMB has built an extensive product range. Developments in their novel approach ensures they can provide the equipment to meet the ever demanding needs of the scientific community. Continual investment in new production, test and design facilities, together with the recruitment and development of key staff, ensures that FMB Oxford remains at the forefront of beamline system supply

Range of services include:

- Feasibility studies
- Engineering and design support including FEA, vibration studies and full integration tests
- Ray-tracing
- Project Management
- ISO 6 cleanrooms for particle free assembly
- In-house manufacturing and test capabilities
- World-wide installation, commissioning and customer service.

In his presentation, **Elliot Jane** outlined the company history and capabilities along with a synopsis of the equipment supplied by FMB Oxford, with a particular focus being placed on mirrors and monochromators. Elliot highlighted some of the measuring methods and data they collect from their equipment to quantify vibration and stability. The talk concluded with the published papers results to date that include real industry data and were followed by a discussion.

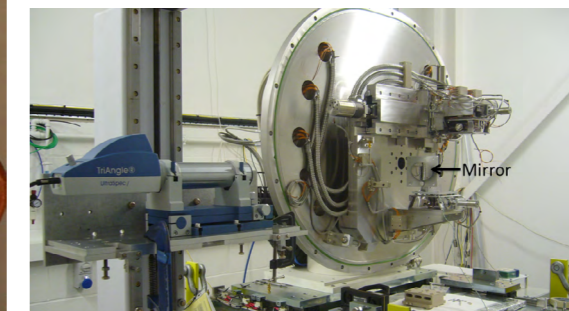
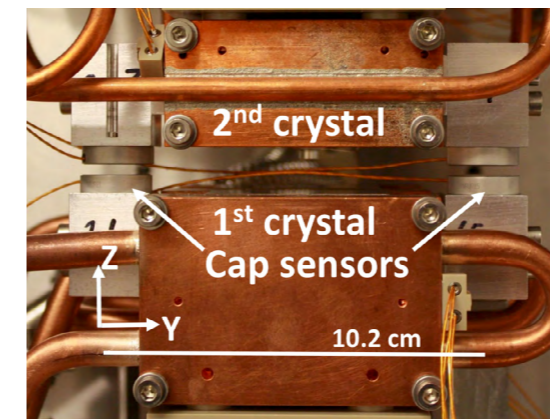
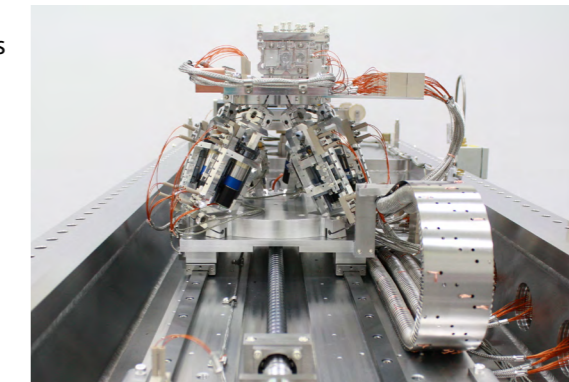

FMB Oxford  
Units 1-4 Ferry Mills  
Osney Mead  
Oxford, OX2 0ES  
United Kingdom

**Scott Mowat**  
Phone: +44 (0)1865 320300  
Fax: +44 (0)1865 320301  
sales@fmb-oxford.com

<http://www.fmb-oxford.com>

# Galli e Morelli

## Officina Meccanica di Precisione

Galli e Morelli - Precision Mechanical Workshop has been collaborating with various research institutes, universities and centers of excellence for over 25 years, participating in the design and construction of experimental equipment for research in fundamental physics.

28

In the context of the collaboration with research institutions, Galli e Morelli - Precision Mechanical Workshop has been actively involved in the development of laser interferometers for gravitational physics, detectors for the study of particle physics and for the realization of precision mechanical elements of modern colliders such as those ones used at CERN in Geneva.

Recently, Galli e Morelli has acquired fundamental expertise in the machining of mechanical elements installed within the modern interferometric detectors for gravitational-wave observations. The company has been deeply involved in the first construction of a complex mechanical system developed by the INFN Pisa Group to isolate optical components from seismic noise within the VIRGO detector (and now Advanced VIRGO, too). Thanks to this experience and to the equipment available at the headquarter, Galli e Morelli can be considered in a limited group of small-intermediate workshops able to build and assemble sophisticated mechanical structures to be operated in high vacuum environment. For all these reasons, the company built similar structures for the California Institute of Technology (LIGO experiment - USA), for the National Astronomical Observatory in Tokyo (TAMA experiment) and for ICRR (KAGRA experiment - Japan).

Galli e Morelli is able to manage complex projects thanks to the well consolidated network with other specialized companies in micromechanics components, in the machining of steel and aluminum structures and in handling sophisticated surface treatments for high precision applications. An expert team of qualified personnel is able to follow all the phases of the working process step-

by-step, starting from the material acquisition up to the final test of any mechanical element to be assembled within a clean-room (if needed) in agreement with the customer requirements and specs. The company is able to machine different materials: traditional ones as well as high-technology materials like Maraging steels, Titanium, Shapal, PEEK, Ceramic, Carbon Fiber and Glass Fiber. The final result of the construction phase is certified by the use of numerical control machines as well as by the continuous controls performed during the intermediate passages and the final test on each produced element.

The continuous technological investment, the daily exchange of ideas with numerous representatives of the scientific world, the enthusiasm that has characterized every challenge faced, have led Galli e Morelli to be today a modern, dynamic and highly reactive company able to offer solutions and high-quality services.



Galli&Morelli srl  
Officina meccanica  
di precisione  
Via Cristofani 558  
Acquacalda  
55100 Lucca  
Italy

Vice-President  
**Alexander Pellicone**  
Phone: +39 (0)583 954 337  
Fax: +39 (0)583 955 273  
alexander.pellicone@  
galliemorelli.com

<http://www.galliemorelli.com/>

# Innoseis

Innoseis is a spin-off company of Nikhef, the Dutch National Institute for Subatomic Physics, and is committed to the transfer of fundamental research to industrial applications.

29

Seismic surveying technology is a crucial link in addressing the energy needs of a growing world population. This technique makes use of large-scale sensor networks to non-invasively image underground structures. In this way, energy companies can effectively pinpoint potential hydrocarbon and geothermal reserves, and utilize existing resources more efficiently.

Innoseis delivers wireless sensor solutions that are designed from the ground up to be ultra-low power and scalable to a million nodes. The ultra-low power performance of their technology means less battery capacity is required resulting in significantly smaller sensor nodes, without compromising on seismic signal fidelity. The cost effectiveness of their technology also provides the industry with the opportunity to constantly monitor production reservoirs to exploit them more effectively and hence greatly increase return on capital expenditure.

Besides ultra-low power sensor networks their expertise also extends to novel (seismic) sensing and read-out techniques including MEMS technology. In addition, their vibration isolation systems are used to generate ultra-low vibration environments.



In the light of ever increasing demand for energy resources companies are looking to sustainably and responsibly tackle challenging environments. Seismic data surveying is a widely used technique for the exploration and study of hydrocarbon and geothermal resources. It utilizes networks with many seismic sensors in order to non-invasively image underground structures. The industry is moving towards even larger networks. Deployment and maintenance costs of cabled network solutions became tremendously large.

Innoseis develops wireless solutions for sensor networks including seismic applications for geophysical applications. The biggest challenges include minimizing the power consumption of the read-out electronics without jeopardizing its performance, and offering a robust and pricing competitive product.

In the future innovative sensors will challenge the dominance of the geophone as the standard vibration detector. MEMS accelerometers with novel designs are under development that have demonstrated world record sensitivity. Their vibration isolated platform provides the ideal test-bed to characterize the performance of such sensors. In addition, the isolation technology is being exported to other fields of research.

In his presentation, **Mark G. Beker** explained how with this technology they have created the 'quietest place on Earth' in their laboratory.



Innoseis BV  
Science Park 105  
1098 XG Amsterdam  
The Netherlands

**Mark G. Beker**  
m.beker@innoseis.com

<http://www.innoseis.com>

# JPE

Development of instrumentation for pioneering research.

JPE is leading expert in precision engineering:

- Applications with high stability demands
- High dynamic positioning
- Positioning in vacuum, cryogenic and magnetic environments.

## Services

With more than 25 years of experience in development of complex instruments for renowned research institutes, JPE is able to provide their customers with solutions to enable pioneering research.

JPE is embedded in a technology & manufacturing hotspot of the world, allowing their strong connections and partners to help them provide you with tailor-made solutions to your specifications to enable your experiments.

## Products

Within their own product-line of positioners and stages, they focus on accurate positioning with nanometric resolution for applications in vacuum and cryogenic environments.

This is a sector where a lot of pioneering research is done by physicists in fields like quantum and elementary-particle physics or gravitational-wave search.

Their products for these environments are:

- Cryogenic positioners & stages
- UHV positioners
- Vibration isolation in cryogenic environment

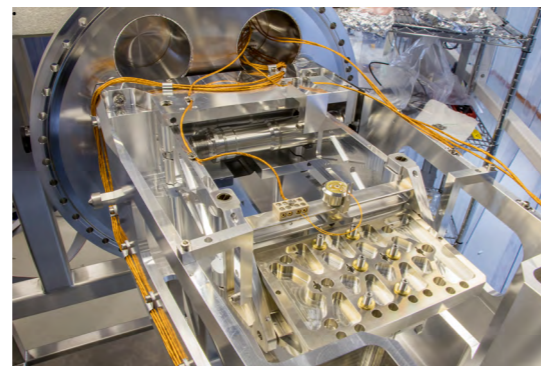

In his presentation, **Bart van Bree** gave a short outline of JPE activities divided in:

- High Tech Engineering with focus on instrumentation development for research institutes
- Cryo & Nano positioning products
- Precision Point, their platform for sharing precision engineering expertise.

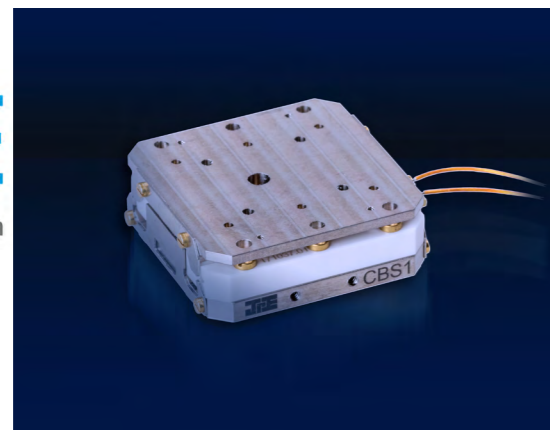

JPE  
Azielaan 12  
6199AG Maastricht-Airport  
The Netherlands

Founder&CEO  
**Huib Janssen**  
Phone: +31 (0)43 35 85 777  
huub.janssen@jpe.nl

<https://www.jpe.nl>

# SmarAct

SmarAct is specialized in the development and manufacturing of customizable high quality micro- and nanopositioning systems and optical metrology instruments.

## Services

SmarAct's high precision positioners are optimized for miniaturization and high stiffness and combine sub-nanometer resolution motion with macroscopic travel-ranges. They can be modified to be used in extreme conditions.

SmarAct utilizes standardized modular stages to construct customized complex positioning systems that can be completely tailored to customer's unique application requirements.

Due to SmarAct's complete in-house design, development and production chain, an outstanding high level of product quality and flexibility is guaranteed. More than 170 employees successfully ensure customer specific positioning and metrology solutions for industrial applications and various scientific fields.

## Products

The product portfolio includes single stages, multiaxial positioning systems, parallel kinematics, miniaturized robots, opto-mechanics and sophisticated metrology equipment based on laser interferometry.

Key features of SmarAct positioners are:

- Backlash-free drives
- Compactness and stiffness
- High dynamic velocity range (up to 20 mm/s)
- Up to 30 N normal load (more upon request)
- Vacuum compatibility down to 10<sup>-11</sup> mbar
- Cryogenic temperature compatibility down to mK range
- Non-magnetic materials available
- Centimeter and meter long traveling ranges
- Encoder resolution options: 1pm...1 nm...  
...4 nm...100 nm...500 nm.

## PICOSCALE: Interferometer and Vibrometer

SmarAct's optical instrumentation (based on a Michelson interferometer) allows for displacement measurements and optical vibration measurements of surface vibrations and vibrational modes of micro- and macro-mechanical components.

Key features PICOSCALE:

- 1 pm resolution
- All optical sensor heads, no electronic components
- Collimated, focused, differential and line focusing beams
- Measurements through layers of Silicon and Gallium Arsenide (infrared laser light)
- Differential measurement possibility
- Low dependency on target reflectivity
- Flexible firmware modules for synchronization and real-time calculation
- Plug and Play measurement and evaluation software packages

In his talk, **Marcel Abheiden** focused on the compensation of dynamic mechanical tolerances of SMARPOD 6-Axis Parallel Kinematics by using a PICOSCALE.



SmarAct GmbH  
Schütte-Lanz-Straße 9  
26135 Oldenburg  
Germany

Managing Director  
**Mr. Axel Kortschack**  
Phone: +49 44 180 087 90  
Fax: +49 44 180 087 921  
info@smaract.com

<http://www.smaract.com>



# VDL

## Enabling Technology Group

VDL Enabling Technologies Group is a tier-one contract manufacturing partner, operating world-wide.

Their goal is to outperform customer expectations in delivering mechatronic solutions.

VDL Enabling Technology Group has built their track record in the following markets: semiconductor capital equipment, thin film deposition equipment for photovoltaic solar systems, analytical instruments, medical systems, aerospace & defense parts and systems and mechanization projects.

To improve the accuracy and repeatability of high-tech equipment, thermal control needs to be further investigated and improved. In his presentation **Paul Blom** focused on charged particle equipment.

He described all aspects of thermal control along the entire product life cycle of charged particle equipment, going from the design phase, via the manufacturing to the service phase.

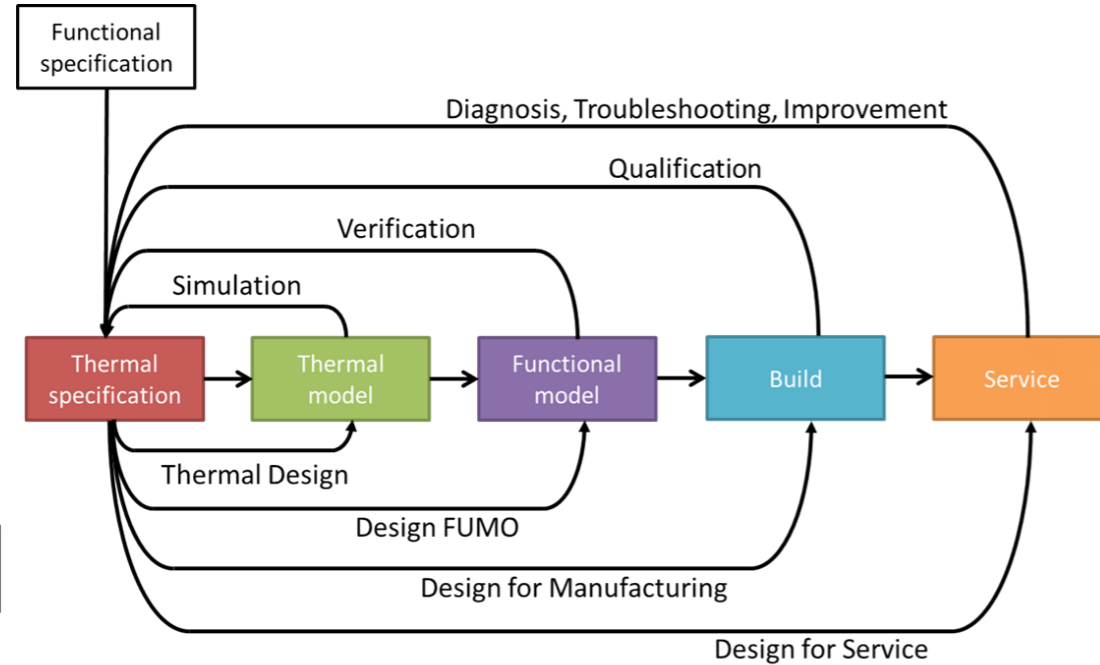

VDL Enabling Technologies Group B.V.  
 Building AQ-156  
 Achtsteweg Noord 5  
 5651GG | Postbox 80038 |  
 5600 JW  
 Eindhoven  
 The Netherlands

Senior System Engineer  
**Paul Blom**  
 Phone: +31 (0)6 12 61 82 35  
 paul.blom@vdlletg.com

<http://www.vdlgroep.com>

# List of participants



<b>Abheiden, Marcel</b>	info@smaract.com	SmarAct GmbH	GERMANY
<b>Beker, Mark</b>	m.beker@innoseis.com	Innoseis	NETHERLANDS
<b>Blom, Paul</b>	paul.blom@vdlletg.com	VDL ETG	NETHERLANDS
<b>Botta, Stephan</b>	stephan.botta@desy.de	DESY	GERMANY
<b>Carelli, Giorgio</b>	giorgio.carelli@unipi.it	University of Pisa, INFN	ITALY
<b>Collette, Christophe</b>	ccollett@ulb.ac.be	Université Libre de Bruxelles	BELGIUM
<b>Daw, Ed</b>	e.daw@sheffield.ac.uk	University of Sheffield	UK
<b>De Kleuver, Job</b>	j.dekleuver@nwo.nl	NWO	NETHERLANDS
<b>Di Girolamo, Beniamino</b>	Beniamino.Di.Girolamo@cern.ch	CERN	SWITZERLAND
<b>Di Virgilio, Angela</b>	angela.divirgilio@pi.infn.it	INFN sezione di Pisa	ITALY
<b>Döhrmann, Ralph</b>	ralph.doehrmann@desy.de	DESY	GERMANY
<b>Frasconi, Franco</b>	franco.frasconi@pi.infn.it	INFN sezione di Pisa	ITALY
<b>Hammond, Giles</b>		University of Glasgow	UK
<b>Hennes, Eric</b>	E.Hennes@nikhef.nl	NIKHEF	NETHERLANDS
<b>Jane, Elliot</b>	Elliot.Jane@FMB-Oxford.com	FMB Oxfröd Limited	UK
<b>Jansen, Alexander</b>	alexander.jansen@kit.edu	KIT	GERMANY
<b>Janssen, Huub</b>	huub.janssen@jpe.nl	JPE	NETHERLANDS
<b>Kittlinger, David</b>	david.kittlinger@mpp.mpg.de	Max-Planck-Institute for Physics	GERMANY
<b>Krieger, Christoph</b>	christoph.krieger@desy.de	University of Hamburg	GERMANY
<b>Krüger, Hilmar</b>		DESY	GERMANY
<b>La Civita, Daniele</b>	daniele.lacivita@xfel.eu	European XFEL	GERMANY
<b>Lee, Chang</b>	changlee@mpp.mpg.de	MPI Physik	GERMANY

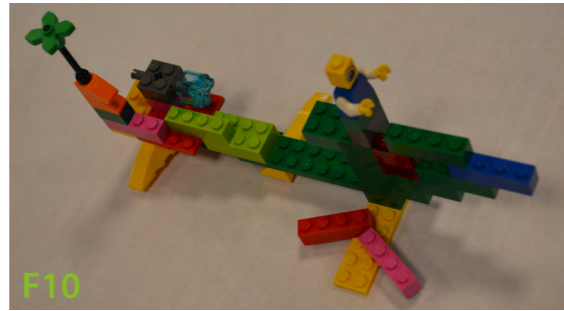

# List of LEGO® constructions and drawings



<b>Miller, Dominik</b>	dominik.miller@desy.de	DESY	GERMANY
<b>Moglia, Francesca</b>	francesca.moglia@desy.de	DESY	GERMANY
<b>Omelcenko, Alexander</b>	omelcenko@smaract.com	SmarAct GmbH	GERMANY
<b>Pellicone, Alexander</b>	alexander.pellicone@gallimorelli.com	G&M	ITALY
<b>Platzer, Roland</b>	roland.platzer@desy.de	DESY	GERMANY
<b>Pöld, Jan Hendrik</b>	jan.pold@desy.de	DESY	GERMANY
<b>Rest, Oliver</b>	o_rest01@uni-muenster.de	WWU Münster	GERMANY
<b>Scheren, Remy</b>	remy.scheren@jpe.nl	JPE	NETHERLANDS
<b>Schlösser, Magnus</b>	magnus.schloesser@kit.edu	KIT	GERMANY
<b>Speet, Pelle</b>	pellespeet@gmail.com	NIKHEF	NETHERLANDS
<b>Van Bakel, Niels</b>	nielsvb@nikhef.nl	NIKHEF	NETHERLANDS
<b>Van Bree, Bart</b>	bart.van.bree@jpe.nl	JPE	NETHERLANDS
<b>Vannoni, Maurizio</b>	maurizio.vannoni@xfel.eu	European XFEL	NETHERLANDS
<b>Visser, Jan</b>	janvs@nikhef.nl	NIKHEF	NETHERLANDS
<b>Wüstling, Sascha</b>	sascha.wuestling@kit.edu	KIT	GERMANY
<b>Zhao, Guoying</b>	guoying.zhao@hotmail.com	Universite Libre de Bruxelles	BELGIUM
<b>Z., C.</b>	info@smaract.com	SmarAct GmbH	GERMANY

- F1** Physics at the limit - In critical situations, the physicist tries anyway to overcome the limits, running some risks in order to expand his/her knowledge.
- F2** LHC and remote station - Ideally, LHC could be driven completely remotely via a suitable station at a certain distance; this foretells a possible development to be discussed in the next ATF about robotics in harsh environments.
- F3** The multimessenger assistant - A platform with a rotational and translational stage is multipurpose and can be applied in experiments in many scientific and technical fields; in seismic measurements, a great importance is given to absolute rotations, harder to measure than the absolute translations.
- F4** The PLI - A representation of the Precision Laser Inclinator developed by CERN and JINR.
- F5** Sketches about MADMAX - The requirements and some suggestions for the assembly of the tiles of the disks composing the haloscope in MADMAX.
- F6** A hexagonal tile for a MADMAX disk - The ideal disk for the experiment is in one single piece, but due to limits in the material production, a disk will be formed by hexagonal tiles connected to each other in the most stable way; here the sub-tiles perfectly connected to each other represents the wished stability in the junctions.
- F7** Suggested disk-production procedure for MADMAX - The full representation of the photolithographic process explained at pages 6-7, with the net representing an exchangeable mask.
- F8** Suggested position-tracking system for MADMAX - The full representation of a possible smart laser-based system, with emitted and reflected beams from the rear side of one disk explained at page 7.
- F9** How science approaches industry - The full representation of how the different players and elements listed at pages 8-9 in the European XFEL facility interact with each other; the vendor is seen as the elephant, poorly flexible and slow, while the specifications are the fan, because they vary easily with time and circumstances.
- F10** Free-mind constructions - Physicists and engineers know LEGO® bricks very well and these are examples of free constructions during the brainstorming session.

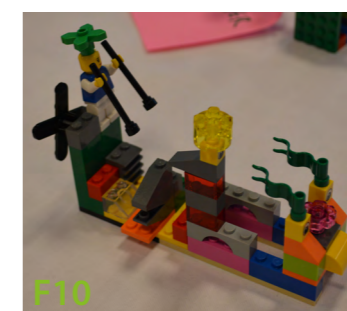



APPEC, the Astroparticle Physics European Consortium, has been founded in 2012 by major funding agencies active in Astroparticle Physics. Ministries, funding agencies or their designated institutions from Belgium, Croatia, Czech Republic, Finland, France, Germany, Greece, Italy, JINR in Russia, Netherlands, Poland, Portugal, Romania, Spain, Sweden, Switzerland, and UK were members of the consortium in 2018. Based on the achievements of the EU-funded ERA-NET ASPERA, the partners of APPEC agreed to coordinate their funding activities and undertake common actions to support Astroparticle Physics in Europe.

The development of a common European strategy for Astroparticle Physics and the update of the roadmap for this research field for the period 2017-2026 are important achievements of APPEC. Related to this, APPEC is continuing to release common calls for funding of common R&D projects and establish a common public outreach. Furthermore, APPEC aims at supporting synergies between Astroparticle Physics and other scientific domains as well as R&D cooperation with industry in Europe.

Astroparticle Physics itself is a young and very active science discipline comprising a lot of R&D activities in advancing detection methods and technologies to the maximum. Programmatically, it is both, performing particle physics with cosmic accelerators and performing astronomy at highest (particle) energies.

Astroparticle physicists search for the tiniest amount of energy released by a dark matter particle in their experiments, fine tune their antennas to discover the infinitesimal small squeezing of the earth when passed by a gravitational wave, and – to the other extreme – build detector arrays of the size of 3000 km<sup>2</sup> to measure the footprint of the most energetic cosmic particles hitting the earth atmosphere.

Altogether, Astroparticle Physics in Europe covers:

- Astronomy at Gamma-ray energies
- Direct dark matter search
- Dark energy surveys
- Gravitational wave astronomy
- Determination of neutrino properties
- Neutrino astronomy
- Determination of the nature and origin of cosmic ray
- Physics of the cosmic microwave background radiation
- Multimessenger astronomy.

# Imprint

## Publisher

Astroparticle Physics European Consortium - APPEC  
represented by  
Deutsches Elektronen-Synchrotron  
DESY - [appec@desy.de](mailto:appec@desy.de)

## Editorial Office

Francesca Moglia, Thomas Berghöfer

## Design and production

Francesca Moglia, Britta von Heintze

## Images and graphics

All images are protected by copyright

The copyright belongs to the respective projects, companies and institutions

### COVER

©KIT - Joachim Wolf

©Innoseis BV

©FMB Berlin for European XFEL

Page 2-3 TOP

©INFN Pisa - M. Kraan and F. Frasconi

©KIT - Markus Breig

© DESY - Heiner Müller-Elsner

Page 3 BOTTOM

©2016 by Sean Blair and Marko Rillo, based on the LEGO® Serious Play® Open Source Guide

made available by the LEGO® Group under a Creative Commons licence

Page 4-5 TOP

© DESY - D. Reipka

©University of Glasgow - G. Hammond

Page 6-7 TOP

©DESY- M. Seyrich FS-PETRA, DESY Nanolab T. Keller and S. Kulkarni (SEM image)

©KIT - Markus Breig

Page 8-9 TOP

©European XFEL - Jan Hosan

©DESY - R. Döhrmann - In-vacuum lens-changing system at PETRA III, Beamline P06

Page 10-11 TOP

©University of Glasgow - G. Hammond; Kelvin Nanotechnology

©European XFEL/ Heiner Müller-Elsner

©KIT - Florian Priester

Page 12 BOTTOM

©KIT - Press Office

©KIT - Florian Priester

# Imprint

Page 13 LEFT

©KATRIN collaboration

©KIT - Joachim Wolf

Page 14-15 LEFT

©KIT - Markus Breig

©KIT - Markus Breig

Page 24 TOP:

©FMB Berlin for European XFEL

## Print

DESY Druckzentrale, March 2019

## Websites

[www.appec.org](http://www.appec.org)

[www.appec.de](http://www.appec.de)





[www.appec.org](http://www.appec.org) | [www.appec.de](http://www.appec.de)